

Model P214 Piston Flow Meter (Analog) 5 cc/min to 10,000 cc/min

SPECIFICATIONS

Flow Range	5 cc/min to 10,000 cc/min
Accuracy (at 3 cP)	± 0.2% of reading over a 200:1 range, or ± 2mV (or 4µA), whichever is greater
Maximum Operating Pressure	210 bar (3000 psi)
Displacement	10.5 cc/rev
Weight	3.8 kg
Recommended Filtration	10 micron
Port Size(s)	3/8" NPT, #6 SAE or manifold mount
Fluids	Most non-aqueous, hydrocarbon based fluids



MATERIALS OF CONSTRUCTION

Body	Stainless steel, type 303
Pistons	Nitride hardened stainless steel, type 303
Crankshaft	Stainless steel
Bearings	All ball bearings, 440C stainless steel
O Rings	Viton®- standard • Teflon®, Perfluoroelastomer - optional

ANALOG TRANSMITTER

Output Signal	Any range of ± 10V or ± 20mA Linearized and damped with anti-dither protection
Power Supply Requirements	Two Models: 12Vdc @ 90 mA, 24Vdc @ 45 mA
Ambient Operational Range	-40°C to 80°C, Single piece – Two piece to 110°C
Metered Liquid Temp Range (based on 20° ambient)	-40°C to 90°C, Standard model -40°C to 225°C, Two piece high temperature model
Compliance	CE Certified, Ex-proof version available with ATEX/IECEx II 2 G Ex db IIB Tx Gb as well as UL, cUL certification for Class 1, Division 1, Groups C and D, Tx

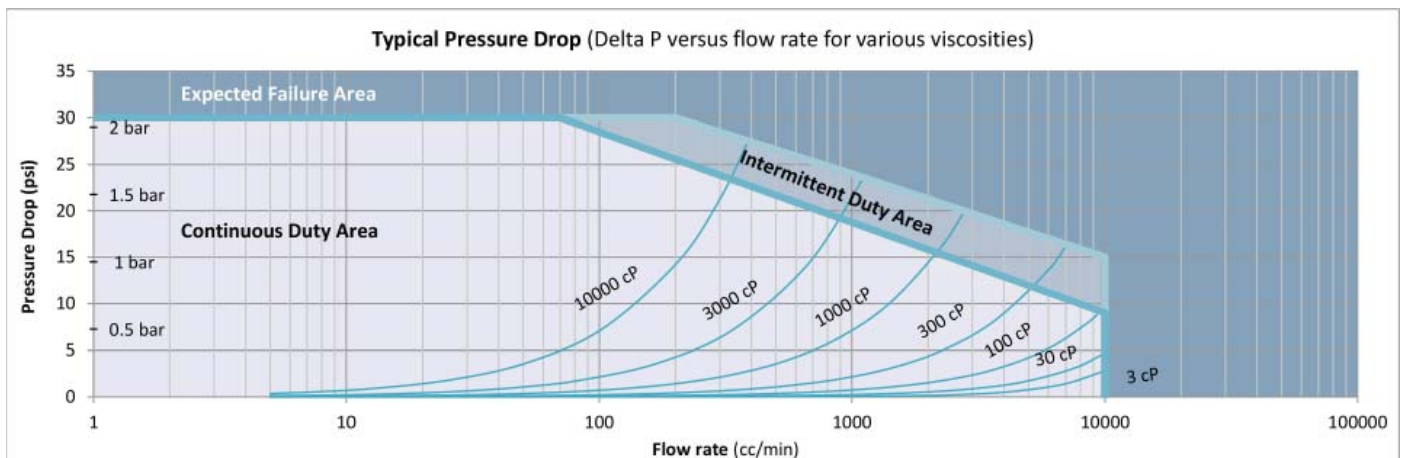

Model P214 Flow Meter (Analog)

CONNECTIVITY/DIMENSIONS (Not to scale)

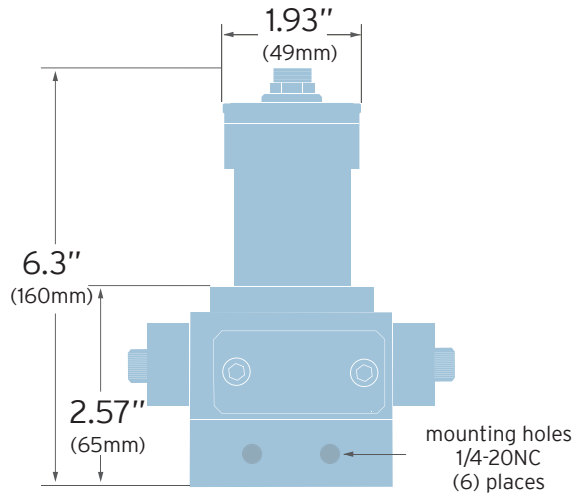

MODEL 214 WITH INDUSTRIAL HOUSING TRANSMITTER

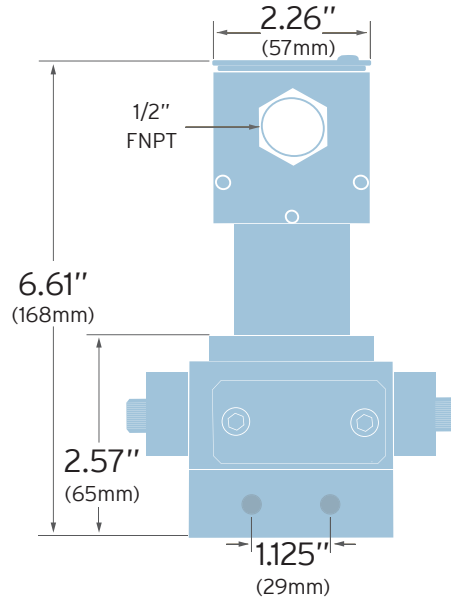

MODEL 214 WITH EX-PROOF HOUSING TRANSMITTER

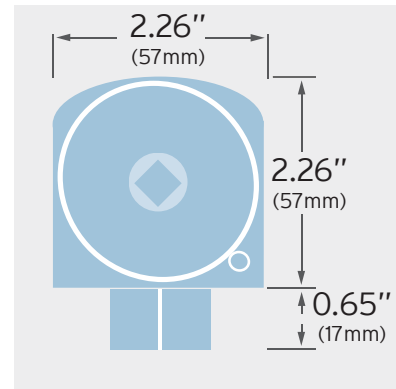
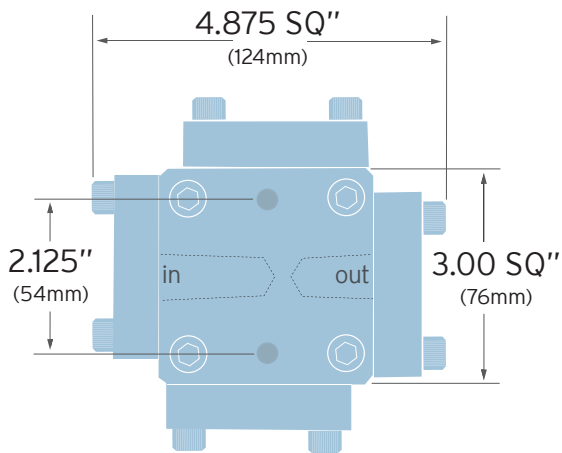

EX-PROOF HOUSING TOP VIEW

ELECTRICAL CONNECTION – ANALOG TRANSMITTERS

	Turck® Connector		
	PCA Label	Pin #	Mating Cable Wire Color
Power *	V+	1	Brown
Common	Com	4	Black
Signal Output (+)	Sig	5	Grey
Signal Output (-)	Ret	2	White
Case Ground	Case	3	Blue

* Please specify 12Vdc or 24Vdc operation

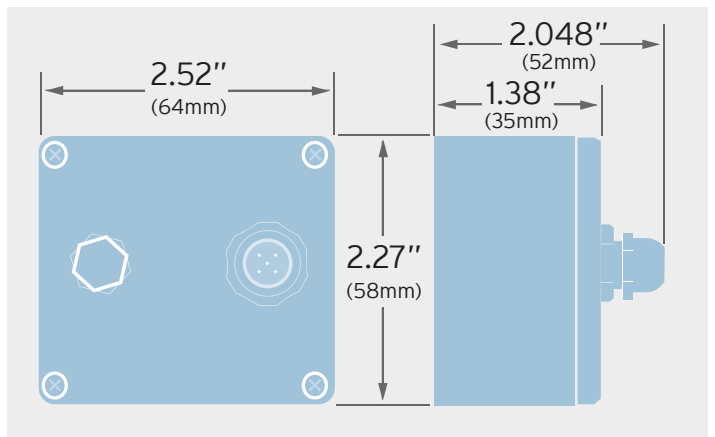

REMOTE PCA ENCLOSURE FOR HIGH TEMPERATURE TRANSMITTERS
(2 meter interconnect cable, not shown)

